

TX series

Class D Power Amplifier

SAE
www.saeaudio.com
Download and share.



The TX series of power amplifiers by SAE Audio are a very versatile and efficient yet affordable option for those requiring an all-purpose device. Implementing Power Factor Correction technology along with Universal Mains Regulated SMPS power supply and Class D power modules, the TX series combines in the same amplifier all the functional requirements found on most sound reinforcement applications.

Technology

Class D

SAE Audio Class D technology implements the most advanced electronics within the smallest form-factor amplifier modules. The Class D amplifiers by SAE Audio implement the most efficient sound amplification technology available today, providing an unmatched system portability and affordability with the best sonic performance.

Universal Mains R-SMPS

SAE Audio renowned Regulated SMPS power supply has been further improved with universal mains operation on all the range from 90V to 260V, eliminating the need for market specific power supplies and related reliability issues. The Universal Mains Regulated SMPS power supply delivers consistent power world-wide.

Power Factor Correction

SAE Audio innovative Power Factor Correction (PFC) technology along with its renowned R-SMPS power supply allows to draw current from the mains in a more efficient way translating to a higher out power with a lower power consumption. Additionally PFC improves audio quality; it generates lower harmonics of the mains frequency thus reducing the hum and induced distortion because of perturbed mains.



Features

- Class D power modules.
- Universal mains Regulated SMPS.
- XLR signal input and link connectors.
- SpeakON NL4 and binding-post output connectors.
- Input sensitivity selector on the back panel (0.775V / 1V / 32dB).
- Routing mode selector on the back panel (stereo / bridge-parallel).
- Mains circuit-breaker on the back panel(only TX5200).
- Channel independent protection and clip warning indicators on the front panel.

- Channel independent power and -5dB/-10dB/-20dB/signal presence indicators on the front panel.
- Low unit weight(TX800-TX3600).

Applications

- Sound reinforcement applications with mid power density and good sounding requirements.
- Small to mid sized bar/café/lounge installation.
- Portable or rental industry PA system.



TX800 rear panel

Specifications

Model	TX800	TX1200	TX2400	TX3600	TX5200
Output power (AC 220V / 50Hz. ±10%, All channels driven output power, THD=1%)					
8Ω Stereo	300W x2*	500W x2*	700W x2*	1000W x2*	1500W x2
4Ω Stereo	500W x2**	850W x2**	1250W x2**	1750W x2**	2500W x2*
8Ω Bridge	1000W**	1700W**	2500W**	3500W**	5000W*

Other specification

Frequency response	20Hz-20KHz (+0/-1dB)				
THD+N	≤ 0.15%	≤ 0.15%	≤ 0.15%	≤ 0.15%	< 0.05%
S/N rate	≥ 100dB	≥ 100dB	≥ 100dB	≥ 100dB	≥ 85dB
Damping factor	≥ 500	≥ 500	≥ 500	≥ 500	> 280
Input sensitivity	0.775 / 1.0V / 32dB				
Input impedance(bal/unbal)	20kΩ / 10kΩ				
Voltage gain (8 ohm)	36dB	38.2dB	39.7dB	41.2dB	43dB
Output circuitry	Class D	Class D	Class D	Class D	Class I™
Cooling	Air flow from front to rear				

Dimension / Weight

Product Dimension(mm)	483 x 306.5 x 89	483 x 306.5 x 89	483 x 306.5 x 89	483 x 306.5 x 89	483 x 506.5 x 133
Packaging Dimension(mm)	560 x 420 x 170	560 x 420 x 170	560 x 420 x 170	560 x 420 x 170	620 x 585 x 210
G.W.	6.9kg	7.2kg	7.45kg	7.9kg	32kg

Dimension (mm)

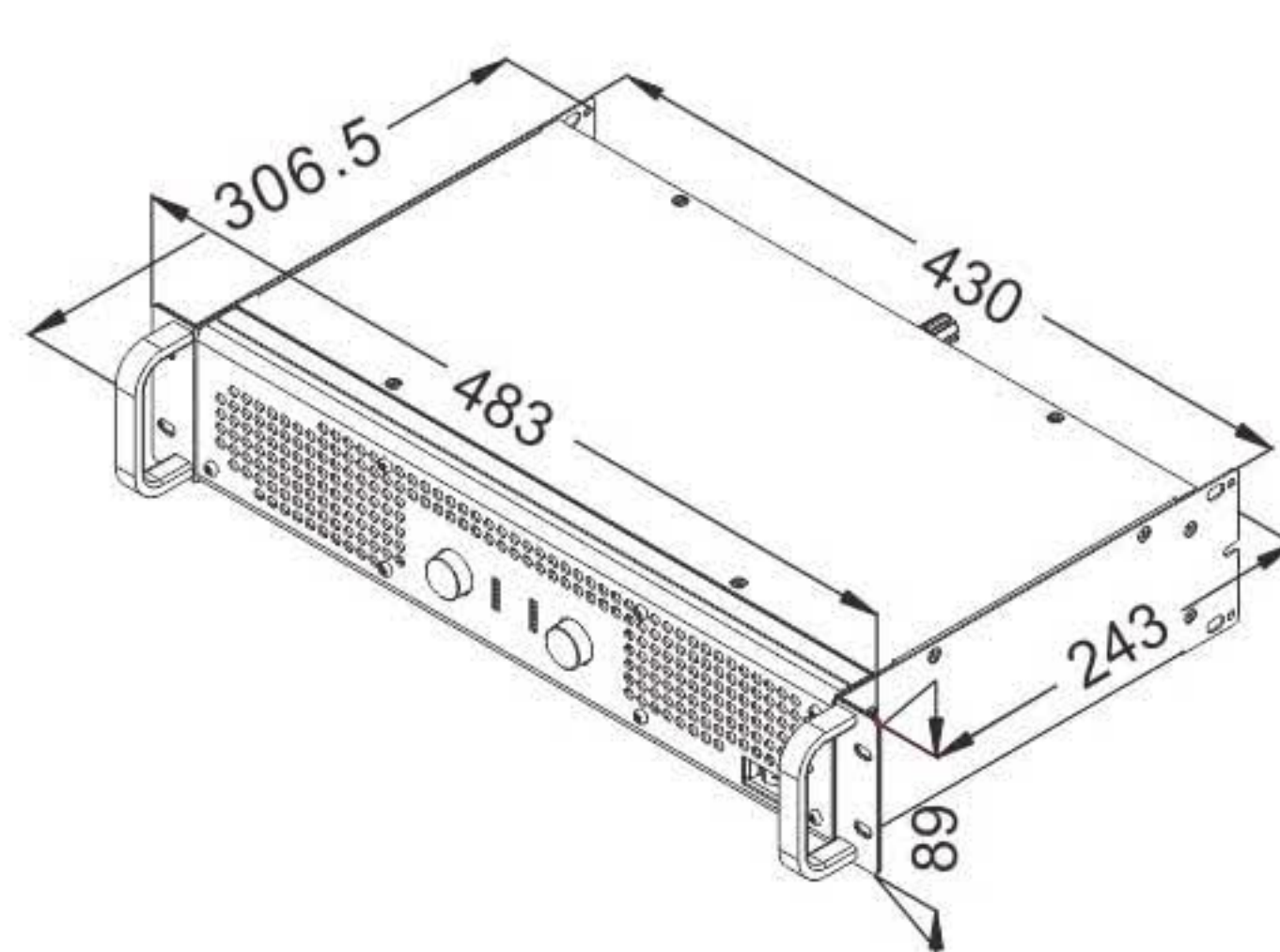

Models : TX800 / TX1200 / TX2400 / TX3600

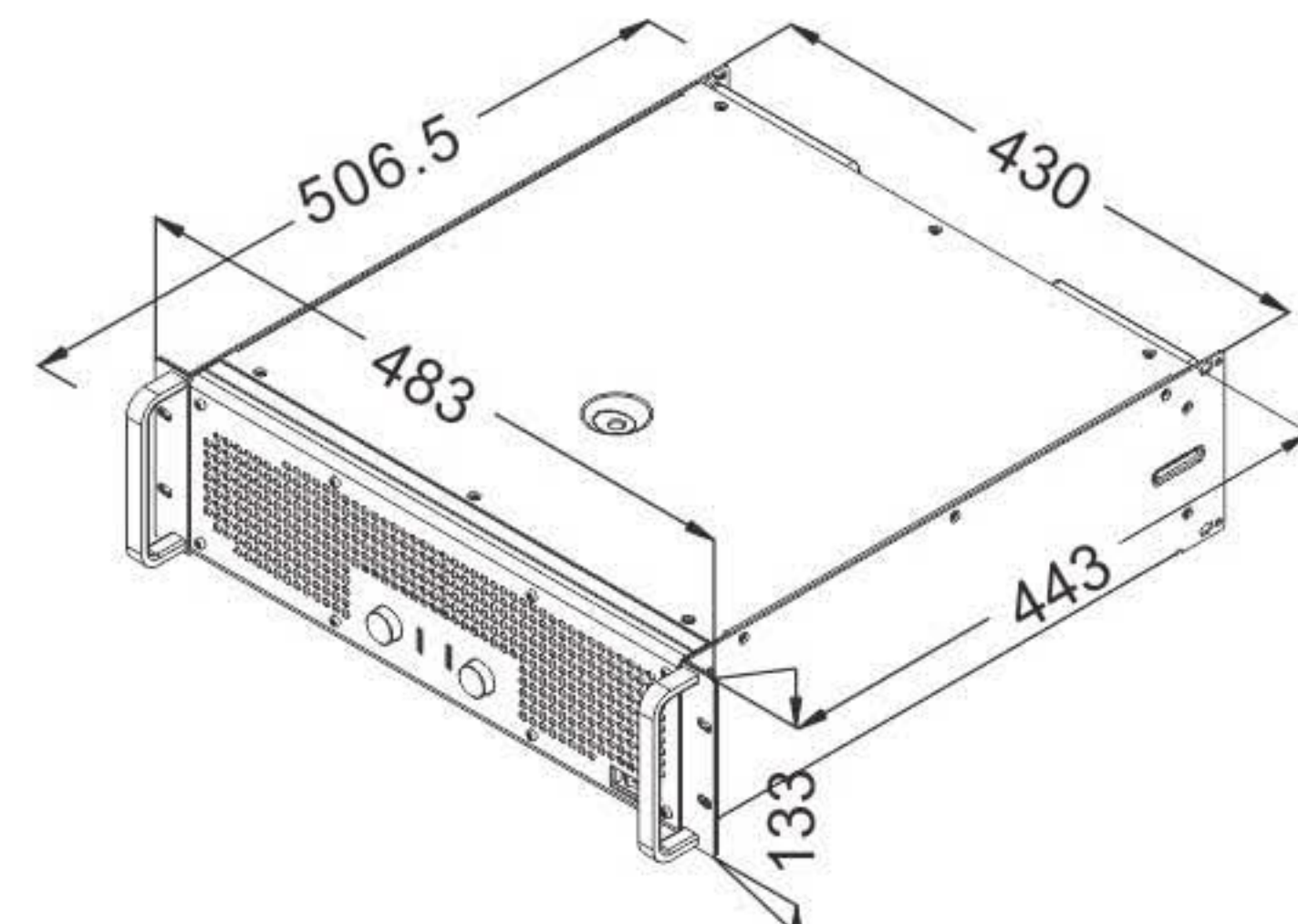

Model : TX5200

- Remark : 1. The power is tested under EIA standard.
 2. *,The power is tested under the condition of 40ms burst,1kHz sine wave and 1% THD.
 3. **,The power is tested under the condition of 20ms burst,1kHz sine wave and 1% THD.
 4. SAE reserves the right to make any changes to the product specifications without prior notice. Final specifications to be found in the user manual.